

**PSET di Lavelli Fabio**  
via Giovanni Alberti, 42/B  
27053 Lungavilla (PV) Italy  
phone: +39.320.0325818  
mail: p-set@outlook.com  
www.p-set.com



# PNEUMATIC POSITIONER USE AND MAINTENANCE MANUAL



**INFORMATION REGARDING CONSULTATION OF THE MANUAL**

A single copy of this manual is supplied on purchasing the machine. Should extra copies be required, the Customer must contact the Manufacturer, quoting the model and serial number of the machine concerned (details to be found on the identification label). This manual was drafted in Italian by the Manufacturer's Technical Department and translated into all the languages of the European Community Countries where the machine is on sale. In the event of disputes or incorrect translation and interpretation, the manual in the language of the Manufacturer's Country shall prevail. Use of the machine concerned requires performance that the User is a person with good professional capabilities and working experience on this type of machine. Should that not be the case, it is indispensable that the User undergoes a course of training for using the machine, either held on the Manufacturer's premises or with a Dealer or, in any case, held by the Manufacturer's qualified staff. This manual is to be considered an integral part of the machine and should therefore always be kept available for consultation and in a dry, safe place, protected from the sun.

The manual includes various safety indications, to make the machine easier and safer to use. To make these easier to understand, they are divided into:

**WARNING:** this term is used to identify any occurrences that may lead to damage to the machine.

**CAUTION:** this term is used to identify any occurrences that may also cause harm to the operator. In some cases these are shown in bold letters.

**N.B.:** this term is used to identify general information regarding the machine and important information for successful production processes.

**CAUTION**



**ALL REQUESTS AND ORDERS FOR ACCESSORIES AND/OR SPARE PARTS FOR THE MACHINE SHOULD BE SENT TO THE MANUFACTURER'S TECHNICAL DEPARTMENT.**

The machine manufacturer reserves the right to make changes to its dimensions, shapes and features at any moment and without advance notice.

**PRINCIPAL WARNINGS WHEN USING THE MACHINE**



This User Manual must be read carefully before carrying out any operation on the machine: its operation by unqualified persons may lead to serious harm to people and damage to objects.



Operations, such as adjustment, fittings and replacements, which require contact with parts of the machine that heat up during processing must be carried out exclusively with the use of protective gloves, to avoid any risk of accident.



Protections have been fitted by the Manufacturer to protect the operator from harm. While the machine is operating, the protections must not be removed for any reason whatsoever.



It is forbidden to tamper with, alter or change, even partially, the machine and the equipment forming the controlling system.



It is extremely important that no unauthorised persons should pass in the vicinity of the machine or, even worse, interfere with any of its components, while it is in operation, in order to avoid accidents.



Pay the utmost attention in the areas of the machine where there is a risk of coming into contact with moving parts, in order to avoid crushing/dragging of upper limbs.



**It is extremely important that no-one, with or without authorisation, should interfere with any of the machine's components while it is in operation, in order to avoid accidents. Such as crushing of hands on the inside when the horizontal bar pulls back at the start of its run.**

**NOTE**

IN THE SUBSEQUENT CHAPTERS, AT THE END OF A PARAGRAPH, A LIST WILL BE FOUND OF APPROPRIATE "CAUTION" INDICATIONS REGARDING THE MOST PARTICULAR RISKS APPLICABLE TO THAT CHAPTER. HOWEVER, THIS DOES NOT MEAN THAT ALL THE AFOREMENTIONED PRINCIPAL WARNINGS SHOULD BE OVERLOOKED. N.B. IT SHOULD NOT BE FORGOTTEN THAT, PURSUANT TO ITALIAN LEGISLATIVE DECREE No. 81/2008, THE USER IS OBLIGED TO CARRY OUT AN ADEQUATE ANALYSIS OF RISKS ARISING FROM OPERATIONS OF THE MACHINE/PERSONNEL AT THE TIME OF COMMISSIONING OF THE MACHINERY IN ITS WORK STATION.

**NOTE**

ALL FORESEEABLE ACTIVITIES WITH THE MACHINE, BOTH FOR TECHNICAL OPERATIONS AND PRODUCTION USE, HAVE UNDERGONE CAREFUL ANALYSIS AT THE DESIGN STAGE, UP TO THE DRAFTING OF THIS MANUAL. NONETHELESS, RESIDUAL RISKS MAY ARISE OVER TIME. THOSE KIND OF RISKS MIGHT ARISE WHICH, ALTHOUGH IDENTIFIED, CANNOT BE ELIMINATED OR SUFFICIENTLY REDUCED BY DESIGN AND AGAINST WHICH PROTECTION IS NOT COMPLETELY EFFECTIVE. THE OPERATOR MUST THEREFORE SERIOUSLY CONSIDER PLACING DANGER SIGNS ON THE MACHINE AND EVERYTHING ELSE THAT IS STATED IN THE MANUAL.

## USER MANUAL INDEX

<b>CHAPTER 1 - GENERAL INFORMATION REGARDING THE USER MANUAL</b>	<b>4</b>
1.1 INTRODUCTION	4
1.2 REFERENCES TO REGULATIONS	4
1.3 PURPOSE OF THE DOCUMENT	4
1.4 USE OF THE MANUAL	4
1.5 OBSERVANCE OF LEGISLATION	4
1.6 SAFEKEEPING OF THE MANUAL	5
1.7 INFORMATION FOR THE USER	5
1.8 CONDITIONS OF GUARANTEE	5
<b>CHAPTER 2 - OVERVIEW OF THE MACHINE</b>	<b>6</b>
2.1 PNEUMATIC POSITIONER	6
2.1.1 POSITIONER OPERATION	7
<b>CHAPTER 3 - OPTIONAL EXTRAS</b>	<b>8</b>
<b>CHAPTER 4 - PROTECTIONS FITTED TO THE MACHINE</b>	<b>8</b>
4.1 PROTECTIONS FITTED TO THE MACHINE	8
4.2 SAFETY SIGNS ATTACHED TO THE MACHINE	9
<b>CHAPTER 5 - RESIDUAL RISKS</b>	<b>9</b>
<b>CHAPTER 6 - FORESEEN AND UNFORESEEN USE</b>	<b>10</b>
6.1 NEGATIVE CONSEQUENCES AND DANGERS OF UNFORESEEN USES	10
<b>CHAPTER 7 - TECHNICAL SPECIFICATIONS</b>	<b>10</b>
7.1 CE IDENTIFICATION LABEL	10
7.2 DIMENSIONS AND PROCESSING DETAILS	11
<b>CHAPTER 8 - COMMISSIONING OF THE MACHINE</b>	<b>14</b>
8.1 PRECAUTIONARY CHECKS ON RECEIPT	14
8.2 CHECK ON THE CONDITION OF THE MACHINE	14
8.3 INSTALLATION OF THE MACHINE	14
<b>CHAPTER 9 - CONNECTION TO EXTERNAL ENERGY SUPPLIES</b>	<b>15</b>
9.1 PNEUMATIC CONNECTION	15
<b>CHAPTER 10 - PREPARING THE MACHINE FOR USE</b>	<b>16</b>
<b>CHAPTER 11 - USING THE MACHINE</b>	<b>16</b>
11.1 OPERATING CYCLE	16
<b>CHAPTER 12 - MACHINE MAINTENANCE</b>	<b>16</b>
12.1 ROUTINE MAINTENANCE	16
<b>CHAPTER 13 - CHECK NOISE LEVEL</b>	<b>17</b>
<b>CHAPTER 14 - DEMOLITION OF THE MACHINE</b>	<b>17</b>

## CHAPTER 1 - GENERAL INFORMATION REGARDING THE USER MANUAL

### 1.1 INTRODUCTION

This manual is a useful aid for familiarising and working correctly with your machine: it should therefore be read carefully before using the machine.

Every machine is sold with its own User Manual. It is the duty of the User to take care of this Manual for the whole life of the machine and not dispose of it until the machine itself is disposed of.

The Manufacturer does not accept liability for any tampering with this Manual or any modifications applied to the machine by the User, after its delivery and not foreseen in this document.

The Manufacturer reserves the intellectual property rights of this Manual and forbids divulgation, whether wholly or in part, in any form whatsoever (print, photocopies, microfilms or other means), as well as processing, reproduction or diffusion through electronic systems, to legal or physical persons, without its approval and registration.

### 1.2 REFERENCES TO REGULATIONS

The Manual has been drafted using the indications contained in these documents:

- **DIRECTIVE 2006/42/EC OF 17/05/2006 – ITALIAN LEGISLATIVE DECREE No. 17 OF 27/01/2010** concerning: HEALTH AND SAFETY AT WORK - Prevention of accidents at work - Machinery.
- **UNI EN ISO 14120 – 2015** concerning: Machine safety - Regulations for drafting and editing safety standards.
- **UNI EN ISO 4414 – 2014** concerning: General rules and requirements on safety for systems and their components.
- **UNI EN ISO 12100 – 2010** concerning: Machine safety - Fundamental concepts - General design principles.
- **UNI EN ISO 13849-1:2016** concerning: Machine safety - Safety-related control system components - Part 1: General design principles.

### 1.3 PURPOSE OF THE DOCUMENT

The purpose of the Manual is to provide the User with the indications and information that have to be strictly adhered to in order to use the machine correctly and ensure the safety of the operator required to interact with it. For this reason the User is kindly requested to:

- make this document available in the workplace and ensure that all operators are familiar with it and have had it shown to them;
- pass on the Manual to subsequent owners of the machine.

### 1.4 USE OF THE MANUAL

This Manual is intended for the User of the machine and those responsible for moving, installing, using, supervising and, at the end of its life, demolishing it. The Manual should be used to demonstrate the use of the machine as foreseen by the theory of its design and its technical features. It provides instructions for moving the machine, installing it satisfactorily and safely, assembling it, making settings and using it; it gives information and guidance for maintenance operations, simplifies ordering spare parts and gives advice about any residual risks.

In particular, it should be constantly available for consultation regarding the following information:

- Anticipated operating conditions for the machine;
- Work station occupied by the operator;
- Instructions regarding: commissioning, use, transportation, installation, assembling and dismantling, making adjustments, maintenance and repair, as well as possible instructions for training.

### 1.5 OBSERVANCE OF LEGISLATION

Apart from the regulations in this Manual, legislative provisions specifically applicable to the field of prevention of accidents in the workplace must be observed.

## 1.6 SAFEKEEPING OF THE MANUAL

The Manual is considered an integral part of the machine and must be kept in good condition until final demolition of the machine. The Manual should be kept available for consultation in a dry, safe place, protected from the sun and must always be made available for consultation, close to the machine.

## 1.7 INFORMATION FOR THE USER

1. This Manual reflects the current technical state of the machine and may not be considered inadequate just because it is updated on the basis of new experiences.
2. The Manufacturer reserves the right to update the production and the manuals, without obligation to update its previous production and manuals.
3. The nature of the materials may be changed at any time, according to technical developments, without giving prior notice.
4. If the machine is supplied without an electrical part for control and protection (electrical switchgear on board the machine), the Manufacturer does not accept liability for safety problems arising from electrical components that do not conform to recommendations and/or requirements. In any case, observance of all Legislation and electrical Standards for equipment accompanying the machine is the exclusive duty of the Customer, who shall fulfil it in accordance with best practice and in a suitable manner for its use.
5. The Manufacturer considers itself exempt of any liability in circumstances where the machine has been:
  - used improperly;
  - used by untrained personnel;
  - used in a manner not complying with what is laid down in this Manual;
  - used in a manner not complying with Standards and Legislation in force;
  - used with defective primary power supply;
  - used with serious shortcomings in the programmed maintenance;
  - used with modifications or operations not explicitly authorised in writing by the Manufacturer;
  - used when fitted with non-original spare parts or ones not specifically dedicated to the model;
  - used with total or partial disregard for the instructions contained in this Manual.

Any request for further copies of this document must be made officially by a purchase order sent to the Manufacturer.

## 1.8 CONDITIONS OF GUARANTEE

The guarantee is valid for 24 months with effect from the date of purchase.

It is limited to the replacement or repair at the indisputable discretion of the company, **PSET DI LAVELLI FABIO**, to any parts proven to be defective from new, either in terms of material or processing.

The guarantee does not include the cost of any transport, labour and travel expenses in connection with any repair or replacement.

**THE GUARANTEE IS AUTOMATICALLY INVALIDATED** when the Purchaser has carried out or had someone else carry out repairs or modifications without prior written authorisation from the company, **PSET DI LAVELLI FABIO**, or has caused damage through negligence and disregard for the attached technical documentation.

The guarantee in no way covers any parts of the machine that are subject to normal wear or which might in any case be seriously damaged by incompetence in the conduct of the operator.

For any parts that are not constructed by the company, **PSET DI LAVELLI FABIO**, such as electric motors, etc, the standard guarantee is passed on to the Purchaser that the respective manufacturers grant on terms laid down by them.

The guarantee is invalidated if the machine is used in a manner that does not conform to the indications and provisions of the manufacturing company.

Any dispute that may arise will be subject exclusively to the jurisdiction of the Court of Milan.

CHAPTER 2 - OVERVIEW OF THE MACHINE

The **PNEUMATIC POSITIONER** designed and constructed by the company, **PSET DI LAVELLI FABIO**, is a machine for placing items to be worked on with maximum accuracy and simplicity, for the benefit of all work sectors requiring specialised manual performance. It ensures greater manual freedom and speed of performance compared to other fixing systems.



FIGURE Chapter 2 - PNEUMATIC POSITIONER

NOTE



This User Manual must be read carefully before carrying out any operation on the machine: its operation by unqualified persons may lead to serious harm to people and damage to objects.

CAUTION



It is extremely important that no unauthorised persons should pass in the vicinity of the machine or, even worse, interfere with any of its components, while it is in operation, in order to avoid accidents.



Protections have been fitted by the Manufacturer to protect the operator from harm. While the machine is operating, the protections must not be removed for any reason whatsoever.



**When the item to be worked on is fixed on the platform, it is highly important that it should be firmly held by hand when the pneumatic valve is activated, because activating the pneumatic valve releases the platform, creating a hazard for the operator.**

2.1 PNEUMATIC POSITIONER

The pneumatic positioner is a support that allows items placed on it to be set in the correct position to be worked on, i.e. sanded, painted and finished off, but exclusively using manual tools.

## 2.1.1 POSITIONER OPERATION

The positioner must be fixed to a stable surface. The item to be worked on is anchored to the platform by means of vices, clamps or other fixing systems.

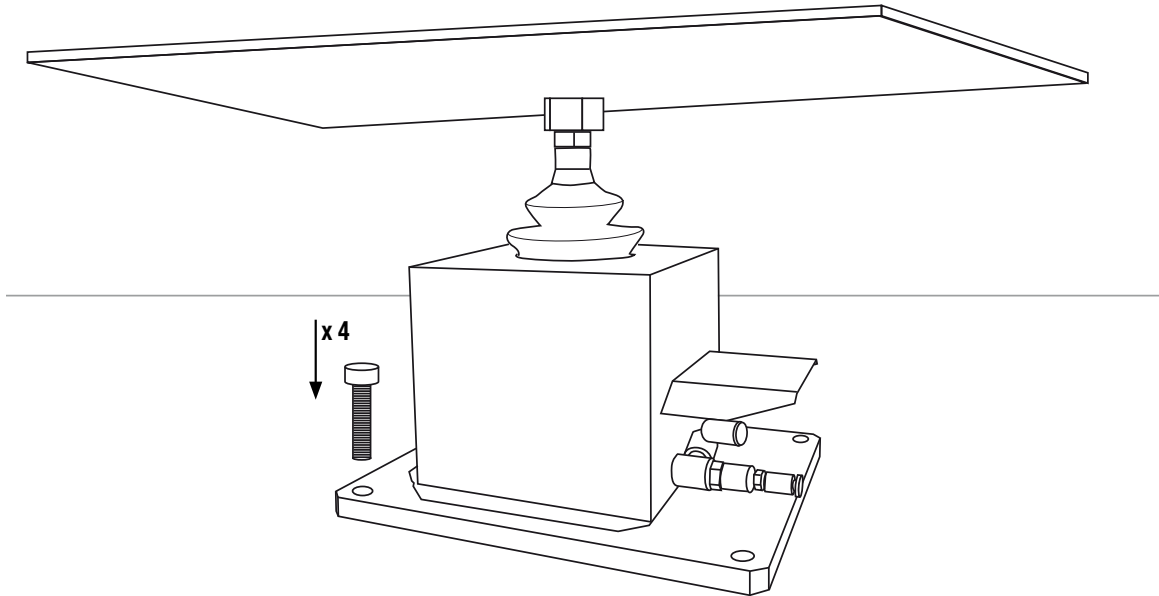

FIGURE Chapter 2.1.1 - POSITIONER OPERATION

When compressed air enters inlet A (T1), the platform changes to the “Lock” position. The platform is fixed and steady in this position. When the device is screwed firmly to its base and the platform is fixed in the “Lock” condition, the item to be worked on may be placed on it. With the item in place, the operator holds it firm by means of vices or clamps. It is simple to fix clamps to the platform using the special slots on its surface.

Operation of a pneumatic valve (2), by foot pedal, lever or mushroom push button (Optional extra), sends a flow of compressed air to port B (T2), which opens the non-return valve, lowers the pressure and removes the locking force. This puts the system into “Neutral” and released from the “Lock” condition, which allows rotation and therefore setting (by hand) of the direction the Platform which is holding the item to be worked on (see page 15).

The non-return valve (3) also acts as a safety valve, in the sense that, if the compressed air is cut off, the platform remains in the “Lock” condition until pneumatic valve (2) is activated to let air into the release port B (T2).

### CAUTION



**When the item to be worked on is fixed on the platform, it is highly important that it should be firmly held by hand when the pneumatic valve is activated, because activating the pneumatic valve releases the platform, creating a hazard for the operator.**

**CHAPTER 3 - OPTIONAL EXTRAS**

The machine may be fitted with a foot pedal for activating the pneumatic system, by request of the customer and with the agreement of the manufacturer. If it is not supplied by agreement, the foot pedal must be purchased on a separate occasion by the purchaser.

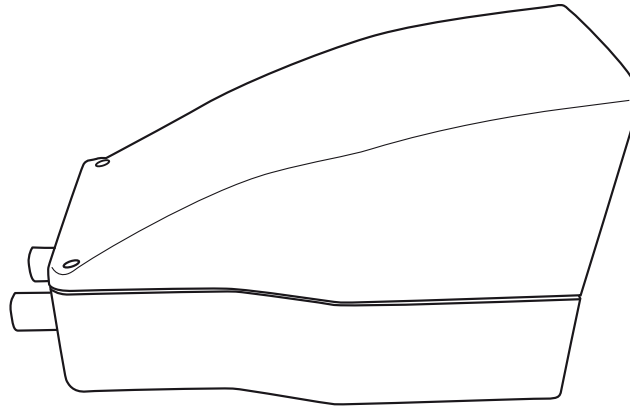

FIGURE Chapter 3 - foot pedal actuator valve - OPTIONAL

**CHAPTER 4 - PROTECTIONS FITTED TO THE MACHINE**

**4.1 PROTECTIONS FITTED TO THE MACHINE**

The Manufacturer has fitted some protections as standard, in order to avoid operators coming into contact, even accidentally, with work elements that may constitute a hazard.

REF.	DESCRIPTION OF PROTECTION
A	The area pertaining to the pneumatic device is closed off by fixed casing.



FIGURE PARAGRAPH 4.1 - PROTECTIONS FITTED TO THE MACHINE

**CAUTION**





IT IS ABSOLUTELY FORBIDDEN to remove the protections fitted as standard by the Manufacturer while the MACHINE is in operation.



#### 4.2 SAFETY SIGNS ATTACHED TO THE MACHINE

As well as the protections, the Manufacturer has taken the step of attaching the following safety signs to the machine at points representing a hazard:

##### SAFETY SIGNS ATTACHED TO THE MACHINE

SIGN	DESCRIPTION OF SIGN	POSITION ON THE MACHINE
	CRUSHING HAZARD	PROTECTIVE CASING
SIGN	DESCRIPTION OF SIGN	POSITION ON THE MACHINE
	PROTECTIVE GLOVES MUST BE WORN	PROTECTIVE CASING
	THE USE AND MAINTENANCE MANUAL MUST BE READ	PROTECTIVE CASING

#### CAUTION



IT IS ABSOLUTELY FORBIDDEN to remove or damage the safety signs attached to the machine.

#### CHAPTER 5 - RESIDUAL RISKS

In spite of the technical considerations regarding safety made in the design and production stage, the machine still proposes certain risks which, by law, are considered residual.

This chapter gives a list of the standards to be complied with in order to avoid hazardous situations, for the operator, for the machine and for the surrounding environment, which may arise from such risks.



#### HAND CRUSHING HAZARD

During work processes, in order to avoid the hazard of crushing/dragging of upper limbs, always pay the utmost attention to movements being made. Before carrying out maintenance work, make sure that pressure has been released from the machine.

## CHAPTER 6 - FORESEEN AND UNFORESEEN USE

The **PNEUMATIC POSITIONER** is a machine designed and constructed by the company, **PSET DI LAVELLI FABIO**, which acts as a support that allows items placed on it to be set in the correct position.

Any other use different from that for which the MACHINE is designed represents an irregular condition and may cause damage to the work equipment and constitute a serious hazard for the operator.

The following actions:

- **improper use of the MACHINE,**
- **special maintenance not carried out by specialised and authorised staff,**
- **removal of labels of any kind,**
- **removal of or tampering with protections or safety features,** will exempt the Manufacturer from any liability and may cause serious harm to persons and damage to objects. Furthermore, the guarantee covering the machine becomes invalid immediately if it is used outside of the aforementioned limits.

### NOTE



**THIS MANUAL IS AN INTEGRAL PART OF THE MACHINE AND IT MUST ALWAYS BE KEPT TOGETHER WITH THE LATTER, EVEN IN THE EVENT OF CHANGE OF OWNERSHIP.**

## 6.1 NEGATIVE CONSEQUENCES AND DANGERS OF UNFORESEEN USES

1. Any working processes not mentioned previously are to be considered improper use of the MACHINE and might cause harm to persons and/or damage to objects.
2. The MACHINE has not been constructed for working in explosive environments, **AND IT IS THEREFORE ABSOLUTELY FORBIDDEN TO USE THE MACHINE IN A POTENTIALLY EXPLOSIVE ATMOSPHERE.**
3. Any element for which no adjustment or replacement is described in this Manual may only be adjusted or modified by personnel from the MACHINE'S Manufacturer or by qualified personnel working under the supervision of the Manufacturer's technicians. As far as commercial off-the-shelf components are concerned, adhere to what is laid down in the respective instruction manuals.
4. In the event of any unintended use of the MACHINE, or in any case, any operations to be carried out on it, it is the duty of the User to seek information from the Manufacturer regarding potential negative consequences or hazards arising from improper use of the MACHINE.
5. It is absolutely forbidden to alter the functional/performance characteristics of the MACHINE and/or its main components in order to increase its productive potential.

## CHAPTER 7 - TECHNICAL SPECIFICATIONS

### 7.1 CE IDENTIFICATION LABEL

As required by the regulations in force, the machine has an identification label attached which bears the following data:

- The Manufacturer's name
- The CE mark
- The year of manufacture
- The serial number

## 7.2 DIMENSIONS AND PROCESSING DETAILS

### 7.2.1 MODEL P3X

TECHNICAL SPECIFICATIONS	U.M.	VALUE
<b>TECHNICAL CHARACTERISTICS OF THE MACHINE</b>		
MAX WORKING PRESSURE	BAR	FROM 4 TO 9

**P3X**

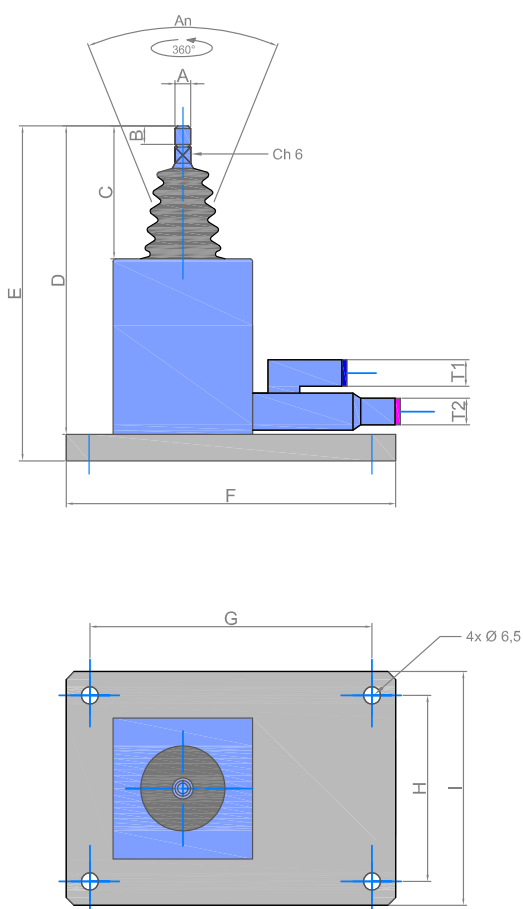

General Dimensions (mm)

A	B	C	D	E	F	G	H	I	T1	T2	An
M 6	7	50	115	123	125	107	70	88	Tu 6	Tu 4	50°

Working Pressure : from 4 to 9 bar Max

Working Temperature: -10° +60°C

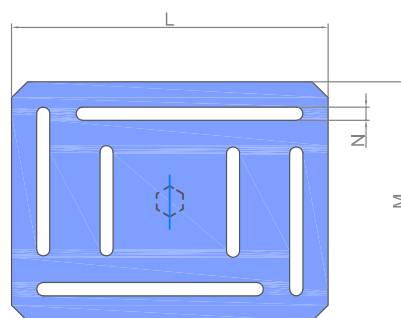
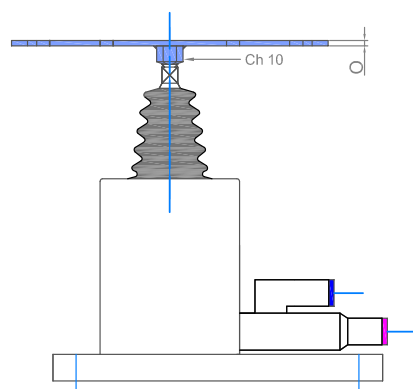

Standard equipment Platform (mm)

L	M	N	O
120	90	5	2

Material : AISI 304

Maximun force allowed (Fr) on the Platform when locked

Y(mm)	60		
bar	4	6	8
Fr (Kg)	2	3	4

7.2.2 MODEL P6S

TECHNICAL SPECIFICATIONS	U.M.	VALUE
<b>TECHNICAL CHARACTERISTICS OF THE MACHINE</b>		
MAX WORKING PRESSURE	BAR	FROM 4 TO 9

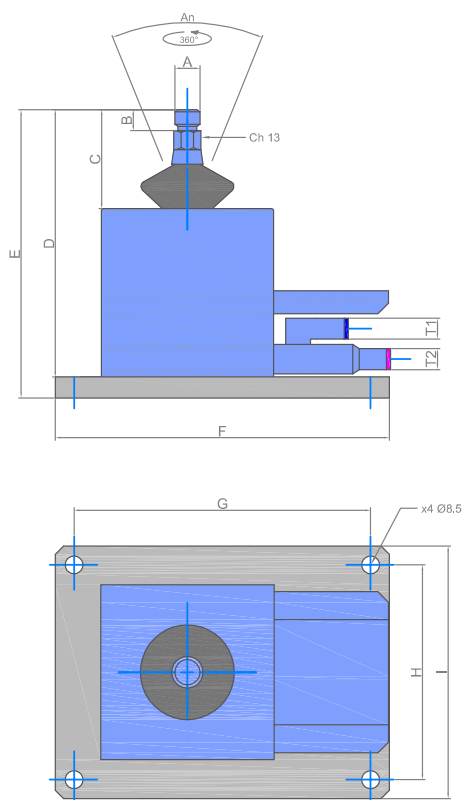

General Dimensions (mm)

A	B	C	D	E	F	G	H	I	T1	T2	An
M12	10	47	125	143	160	142	102	120	Tu 6	Tu 4	70°

Working Pressure : from 4 to 9 bar Max  
 Working Temperature: -10° +60°C

**P6S**

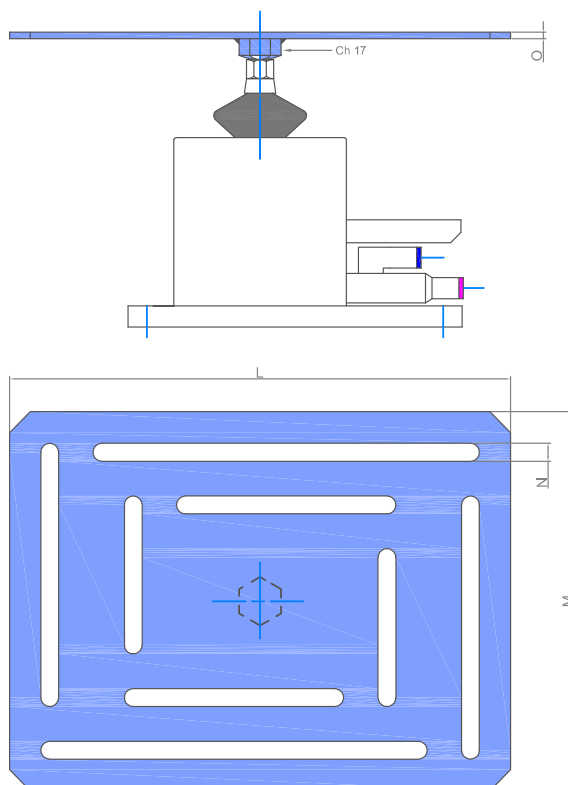

Standard equipment Platform (mm)

L	M	N	O
240	180	8,5	3

Material : AISI 304

Maximun force allowed (Fr) on the Platform when locked

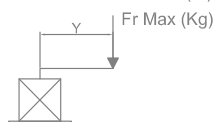

Y(mm)	100		
bar	4	6	8
Fr (Kg)	15	20	27

7.2.3 MODEL P10S

TECHNICAL SPECIFICATIONS	U.M.	VALUE
<b>TECHNICAL CHARACTERISTICS OF THE MACHINE</b>		
MAX WORKING PRESSURE	BAR	FROM 4 TO 9

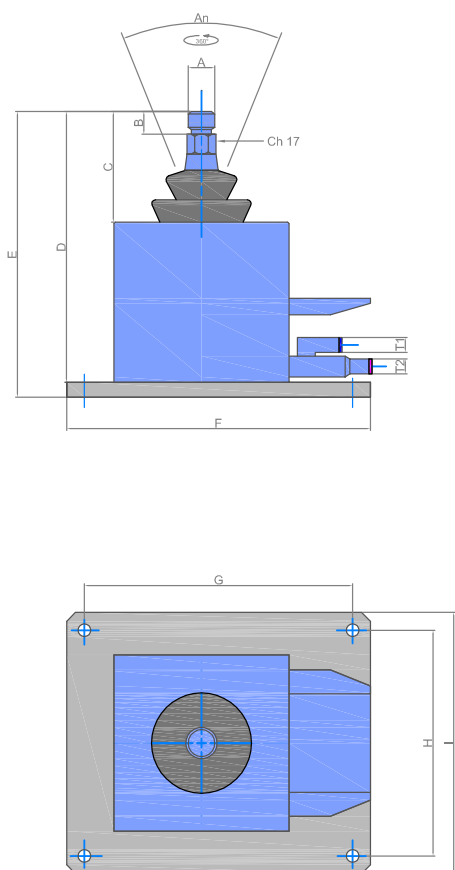

General Dimensions (mm)

A	B	C	D	E	F	G	H	I	T1	T2	An
M18	16	74	190	200	205	181	151	175	Tu 6	Tu 4	70°

Working Pressure : from 4 to 9 bar Max  
 Working Temperature: -10° +60°C

P10S

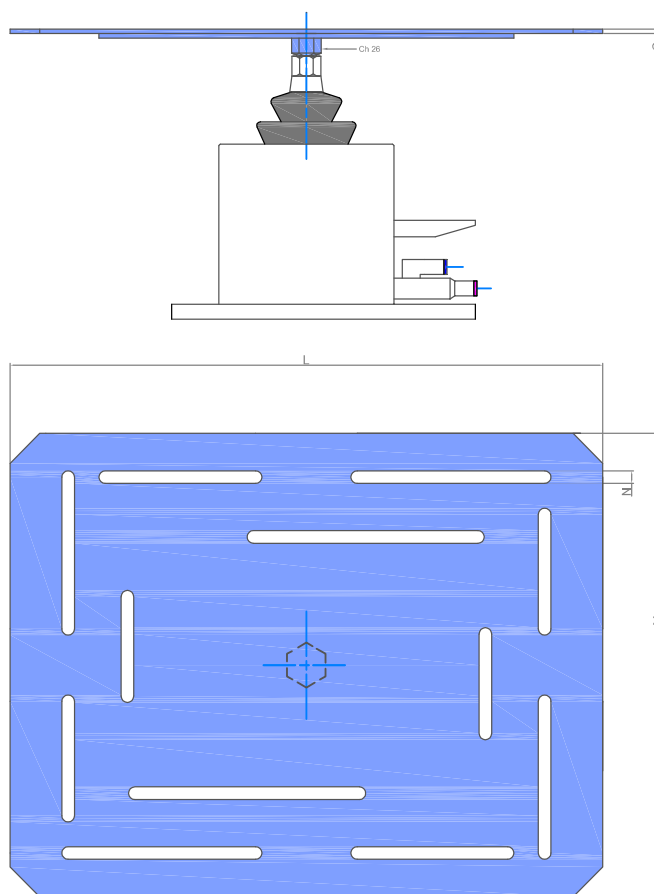

Standard equipment Platform (mm)

L	M	N	O
400	310	8,5	3

Material : AISI 304

Maximum force allowed (Fr) on the Platform when locked

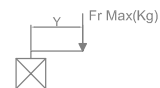

Y(mm)	Fr Max(Kg)		
150			
bar	4	6	8
Fr (Kg)	30	42	55

NOTE



THE DIMENSIONS OF SPACE REQUIRED SHOWN IN THE TABLE ARE INDICATIONS ONLY. THE MACHINE MANUFACTURER RESERVES THE RIGHT TO MAKE CHANGES TO THE DIMENSIONS SHAPE AND FEATURES OF THE MACHINE AT ANY TIME AND WITHOUT ADVANCE NOTICE.

## CHAPTER 8 - COMMISSIONING OF THE MACHINE

### 8.1 PRECAUTIONARY CHECKS ON RECEIPT

When the machine arrives on the premises where it is to be installed, it is advisable to:

- ✓ Check that all the documents have been delivered together with the machine, as required by law, such as:
  - This user manual;
  - The pneumatic diagrams;
  - The declaration of conformity;
  
- ✓ If a request was made for the supply of a series of spare parts, check that they are included;
- ✓ If a request was made for the supply of optional extras, check that they are included.

### 8.2 CHECK ON THE CONDITION OF THE MACHINE

After checking the documents and in order to reveal any possible damage incurred during transportation, it is advisable to make a careful check on the condition of the MACHINE, to be sure that no damage has been incurred by delicate parts, some of which are listed here:

- Loading platform;
- Pneumatic actuator valve.

If any damage to the packaging is evident, proceed as follows:

- DAMAGE VISIBLE ON THE OUTSIDE OR INDIVIDUAL ITEMS MISSING:** these must be reported, immediately after delivery, to the carrier, or haulier, etc., and confirmed in writing in the waybill;
- DAMAGE THAT IS NOT EVIDENT IMMEDIATELY:** this must be reported to the carrier, or haulier, etc. within the time period permitted by law.
- SERIOUS DAMAGE:** an inspection report is required to be carried out by a technical expert appointed by the haulier, by the carrier or by their respective insurance company.

#### WARNING



**Complaints concerning any missing material that should be included, must be received within the time limits laid down in the purchasing contract.**

### 8.3 INSTALLATION OF THE MACHINE

The MACHINE must be installed in a position where the optimal conditions for the well-being of the operators are observed, so as to reduce the possibility of tiredness to a minimum and allow those operators to work in conditions of utmost safety.

Any element that is unfavourable for the workers' capacity for concentration, annoying noises or poor lighting for example, must therefore be eliminated at source.

CHAPTER 9 - CONNECTION TO EXTERNAL ENERGY SUPPLIES

9.1 PNEUMATIC CONNECTION

For operation of all components on board the machine, pneumatic energy must be fed to the **NON-RETURN VALVE (3)** by means of hoses connected to a compressed air source.

**WHEN MAKING THE PNEUMATIC CONNECTION, MAINTAIN THE PRESSURE VALUES CORRESPONDING TO WHAT IS SHOWN IN THIS MANUAL.**

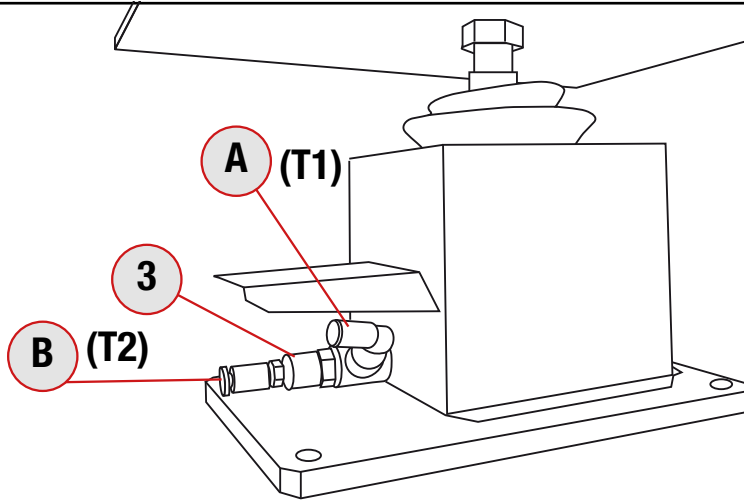

Starting from **Valve 2**, in the form of a foot pedal or a lever or a mushroom push button (Optional extra), connect the air outlets by hoses to the inlets on the **Non-return valve 3**:

**A (T1)** > Main compressed air source.

and

**B (T2)** > Pilot secondary port.

Connect **Valve 2** to the compressed air source (compressor or network system).

The compressed air will now flow directly through the **Valves 2 and 3** into the device.

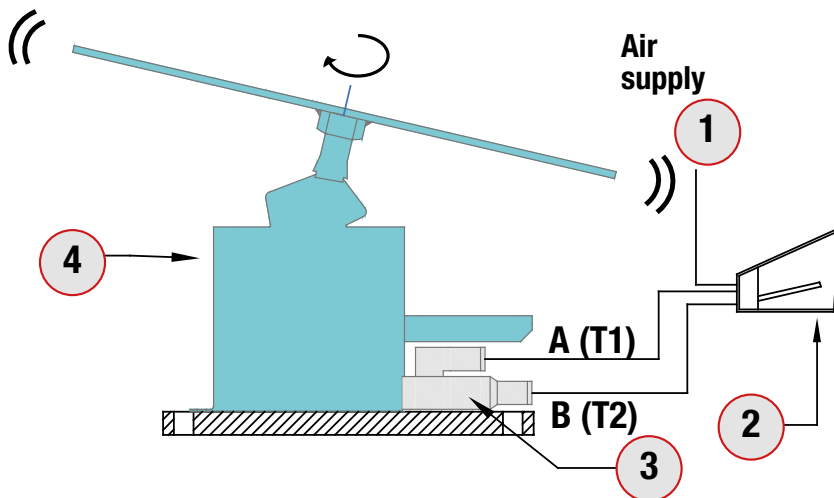

A (T1): Compressed air source

B (T2): Pilot Port

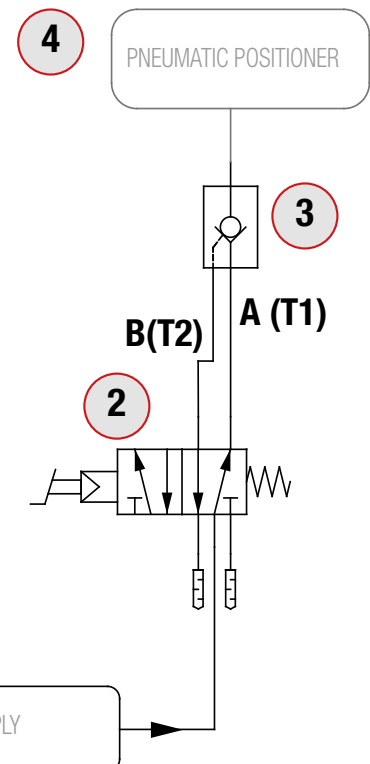

## CHAPTER 10 - PREPARING THE MACHINE FOR USE

Once the machine has been placed in the working area and has been connected to the external energy supplies (see **CHAPTER 9 - CONNECTION TO EXTERNAL ENERGY SUPPLIES**), but before carrying out a work cycle, a check must be done to see that all the micro-switches are functioning and that the protections are in place on the machine.

## CHAPTER 11 - USING THE MACHINE

### 11.1 OPERATING CYCLE

1. Attach the device to a stable surface
2. Check that the conditions described in CHAPTER 10 - **PREPARING THE MACHINE FOR USE** are being met;
3. Connect the foot pedal actuator valve or the manual control to the air outlet valve and connect the air source to the actuator valve;
4. Place and hold the item to be processed on the platform.

#### CAUTION



While it is in operation, no-one except the authorised operator must stand in the vicinity of the Machine or, worse still, interfere with it.



It is **ABSOLUTELY FORBIDDEN** to remove the protections fitted as standard by the Manufacturer while the Machine is in operation.

## CHAPTER 12 - MACHINE MAINTENANCE

This chapter gives a list of all the maintenance and adjustment operations to be carried out on the MACHINE in order to ensure that it functions efficiently and lasts longer.

Please also remember that all operations of maintenance, adjustment and replacement that have not been dealt with in this User Manual **MUST BE CARRIED OUT EXCLUSIVELY BY QUALIFIED PERSONNEL WHILE THE MACHINE IS IN A CONDITION OF SAFETY, THAT IS WITH NO POSSIBILITY OF PNEUMATICS BEING SWITCHED ON AND WITH PRESSURE RELEASED.**

#### CAUTION



While carrying out operations of maintenance, replacements and adjustments, use personal protection equipment.



Modifications and special maintenance other than the maintenance and replacement operations shown in this chapter must not be carried out without first having consulted the Manufacturer, which may or may not give its approval, depending on the circumstances, or may suggest calling in one of its qualified technicians. Please bear in mind that mistaken operations may lead to a state of irregular functioning, cause damage to the machine and represent a source of risk for the personnel authorised to operate it. The Manufacturer therefore denies any liability for anything that may result from the aforementioned operations.

### 12.1 ROUTINE MAINTENANCE

#### DAILY MAINTENANCE

- ✓ CLEAN THE WHOLE MACHINE CAREFULLY TO REMOVE ANY REMAINING RESIDUAL MATERIAL, USING ONLY DAMP CLOTHS MOISTENED WITH WATER AND SPECIAL PRODUCTS SUITABLE FOR CLEANING.



## **ANNUAL MAINTENANCE**

- ✓ CHECK CAREFULLY THAT ALL FIXING SCREWS AND BOLTS ARE FULLY TIGHTENED AND THAT THERE IS NO DAMAGE TO COMPONENTS ON THE MACHINE.

---

## **CHAPTER 13 - CHECK NOISE LEVEL**

Taking into consideration:

- the separate parts making up the Machine,
- the type of processing done by the Machine,
- the nature of the product being processed,

the noise level of the **PNEUMATIC POSITIONER** during normal operation is deemed to be lower than the maximum levels permitted by regulations in force.

---

## **CHAPTER 14 - DEMOLITION OF THE MACHINE**

If it is intended, for any reason whatsoever, to decommission the machine and demolish it, certain basic rules have to be observed, in order to protect our health and the environment we live in:

- Insulation, flexible sheathing and components made in plastic, or non-metallic, materials should be removed and disposed of separately.
- Pneumatic components, switches etc. should be removed for recycling, if they are still in good condition or, if possible, reconditioned and recycled.
- The structure, and in any case all the metallic parts of the machine should be removed and grouped together according to their material. The various parts obtained in this manner may then be destroyed and melted down for recycling of the materials that had made up the original machine.

### **NOTE**



The responsibility for any re-use of certain parts of the machine, for example the motors or the pneumatic pistons, rests exclusively with the User.



The Manufacturer is in no way liable for damage caused to the machine in the event of it being used without certain components or being used for a purpose that is not expressly specified in this manual.



For demolition of any machines that may be connected to this machine, the instructions in their respective user manuals should be followed.



**IN ANY CASE, REGULATIONS IN FORCE IN THE USER'S COUNTRY CONCERNING DISPOSAL OF THE MATERIALS THE MACHINE IS COMPOSED OF MUST BE OBSERVED.**

### **ALL RIGHTS RESERVED.**

NO PART OF THIS MANUAL MAY BE REPRODUCED IN ANY FORM, WHETHER ELECTRONIC OR MECHANICAL, FOR ANY USE WHATSOEVER, WITHOUT THE PRIOR WRITTEN CONSENT OF THE MANUFACTURER.



**PSET di Lavelli Fabio**

Via Giovanni Alberti, n° 42/B - 27053 Lungavilla (PV) - ITALY Ph.: +39 320 032 5818

Email: [p-set@outlook.com](mailto:p-set@outlook.com) | Web: [www.p-set.com](http://www.p-set.com)

**ANNEX I - EC DECLARATION**

# DICHIARAZIONE DI CONFORMITÀ CE

(ai sensi dell'allegato II.a – della direttiva 2006/42/CE sulle macchine)

Il Sig.:

**FABIO LAVELLI**

Titolare della ditta:

**PSET DI LAVELLI FABIO**

Sede legale ed operativa: Via Alberti, 42/B – 27053 Lungavilla (PV)

Tel. 347.8831985 – Fax – E-mail: p-set@outlook.com

**DICHIARA SOTTO LA PROPRIA RESPONSABILITÀ CHE LA SEGUENTE MACCHINA:**

**POSIZIONATORE PNEUMATICO COMPATTO** **MODELLI: P3X - P6S - P10S**

*Descrizione*

*Modello*

2018

*Serie/Matricola*

*Anno costruzione*

*Revisione*

**POSIZIONATORE PNEUMATICO COMPATTO**

*Denominazione commerciale*

**PER POSIZIONARE AL MEGLIO UN OGGETTO CHE ANDRÀ LAVORATO ESCLUSIVAMENTE CON UTENSILI MANUALI**

*Uso previsto*

## È PROGETTATA E COSTRUITA IN CONFORMITÀ

- A TUTTE LE DISPOSIZIONI PERTINENTI DELLA DIRETTIVA 2006/42/CE – DIRETTIVA MACCHINE

e che sono state applicate le seguenti **NORME ARMONIZZATE**:

UNI EN 349 – 2008 / UNI EN ISO 14120 – 2015 / UNI EN ISO 4414 – 2014 / UNI EN 14119 – 2013 / UNI EN ISO 12100 – 2010 / [UNI EN ISO 13849-1:2016](#) / UNI EN ISO 13857 – MARZO 2008

**E CHE IL FASCICOLO TECNICO DELLA COSTRUZIONE DA LUI REDATTO È CUSTODITO PRESSO :**

**PSET DI LAVELLI FABIO**

*Azienda/Società/Tecnico specializzato*

VIA ALBERTI, 42/B

27053

PV

*Indirizzo*

*Cap*

*Provincia*

LUNGAVILLA

ITALIA

*Città*

*Stato*

Luogo e data del documento

LUNGAVILLA 19/12/2018

Il fabbricante

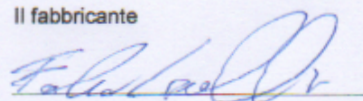



**PSET di Lavelli Fabio**

Via Giovanni Alberti, n° 42/B - 27053 Lungavilla (PV) - ITALY Ph.: +39 320 032 5818

Email: [p-set@outlook.com](mailto:p-set@outlook.com) | Web: [www.p-set.com](http://www.p-set.com)

## ANNEX II - PNEUMATIC DIAGRAM

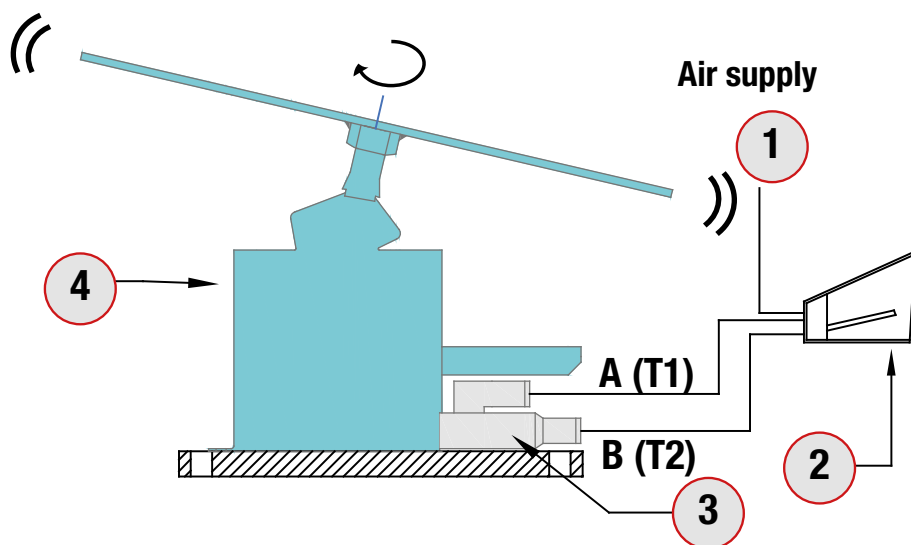

LEGEND

1 - AIR SUPPLY

2 - ACTUATION VALVE - PEDAL (air connection for air supply is for tube  $\varnothing$  8 mm, th. 1,25 mm)

3 - NON-RETURN VALVE

T1 - MAIN COMPRESSED AIR CONNECTION (air connection for tube  $\varnothing$  6 mm, th. 1 mm)

T2 - SECONDARY PILOT CONNECTION (air connection for tube  $\varnothing$  4 mm, th. 1 mm)

Air hoses material recommended: POLYURETHANE

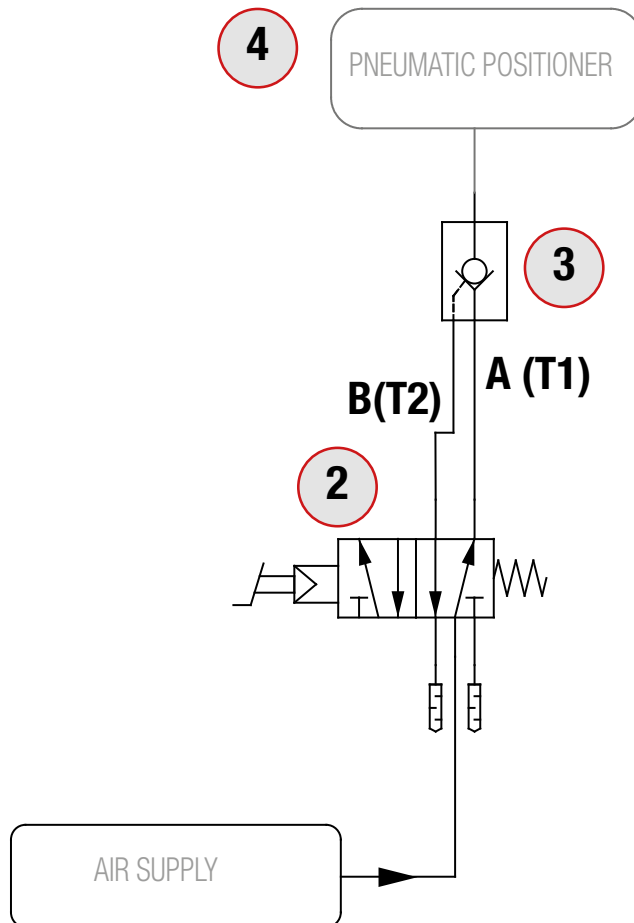



**PSET di Lavelli Fabio**

Via Giovanni Alberti, n° 42/B - 27053 Lungavilla (PV) - ITALY Ph.: +39 320 032 5818

Email: [p-set@outlook.com](mailto:p-set@outlook.com) | Web: [www.p-set.com](http://www.p-set.com)

## ANNEX III - MACHINE DESIGNS

P3X

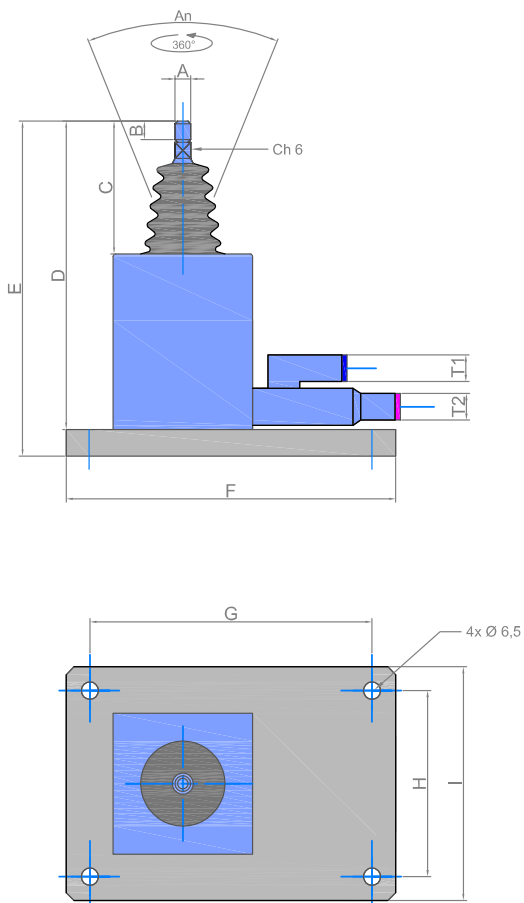

General Dimensions (mm)

A	B	C	D	E	F	G	H	I	T1	T2	An
M 6	7	50	115	123	125	107	70	88	Tu 6	Tu 4	50°

Working Pressure : from 4 to 9 bar Max

Working Temperature: -10° +60°C

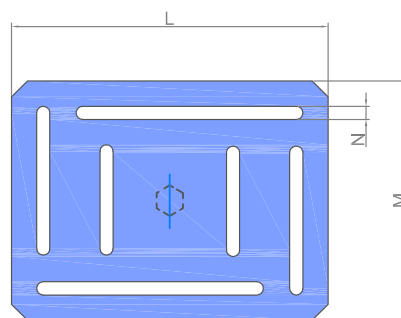
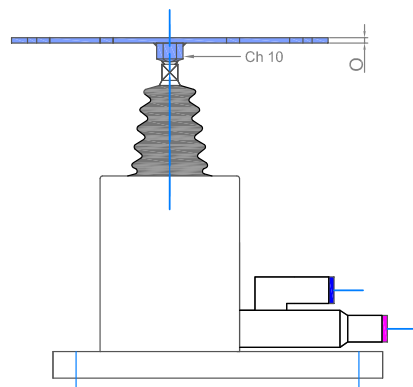

Standard equipment Platform (mm)

L	M	N	O
120	90	5	2

Material : AISI 304

Maximun force allowed (Fr) on the Platform when locked

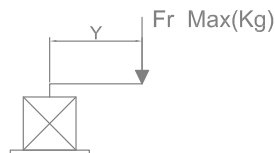

Y(mm)	60		
bar	4	6	8
Fr (Kg)	2	3	4



**PSET di Lavelli Fabio**

Via Giovanni Alberti, n° 42/B - 27053 Lungavilla (PV) - ITALY Ph.: +39 320 032 5818

Email: [p-set@outlook.com](mailto:p-set@outlook.com) | Web: [www.p-set.com](http://www.p-set.com)

**ANNEX III - MACHINE DESIGNS**



P6S

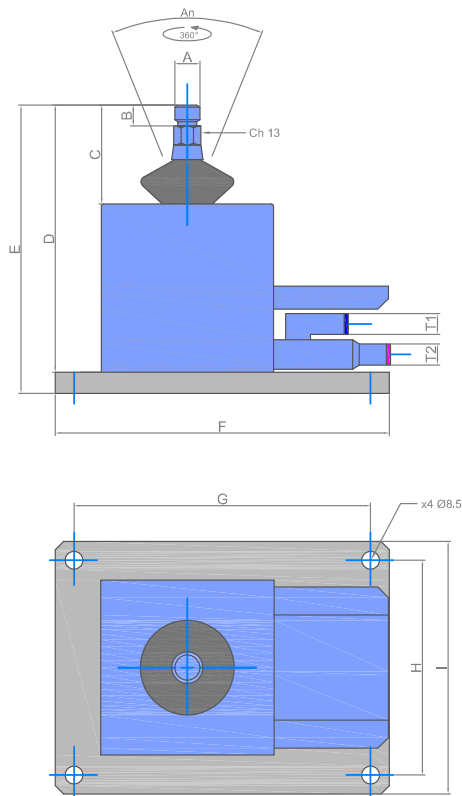

General Dimensions (mm)

A	B	C	D	E	F	G	H	I	T1	T2	An
M12	10	47	125	143	160	142	102	120	Tu 6	Tu 4	70°

Working Pressure : from 4 to 9 bar Max  
 Working Temperature: -10° +60°C

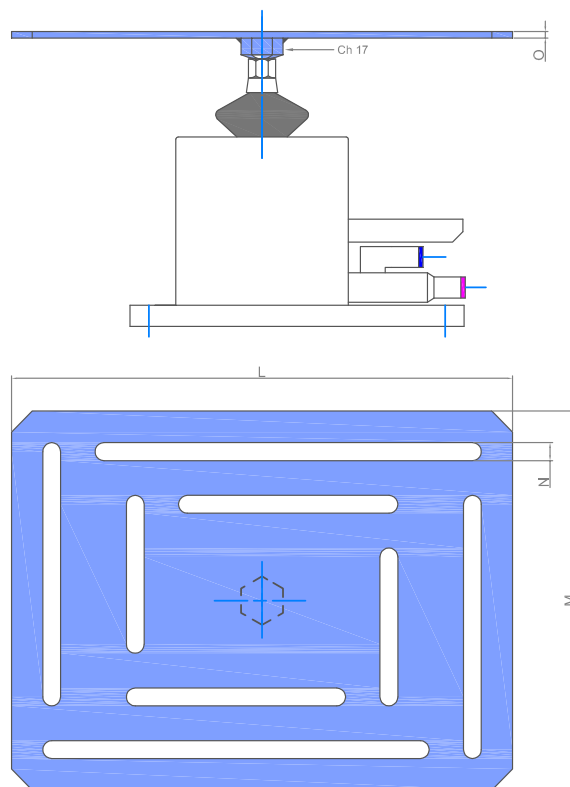

Standard equipment Platform (mm)

L	M	N	O
240	180	8,5	3

Material : AISI 304

Maximun force allowed (Fr) on the Platform when locked

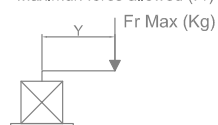

Y(mm)	100		
bar	4	6	8
Fr (Kg)	15	20	27



**PSET di Lavelli Fabio**

Via Giovanni Alberti, n° 42/B - 27053 Lungavilla (PV) - ITALY Ph.: +39 320 032 5818

Email: [p-set@outlook.com](mailto:p-set@outlook.com) | Web: [www.p-set.com](http://www.p-set.com)

## ANNEX III - MACHINE DESIGNS

P10S

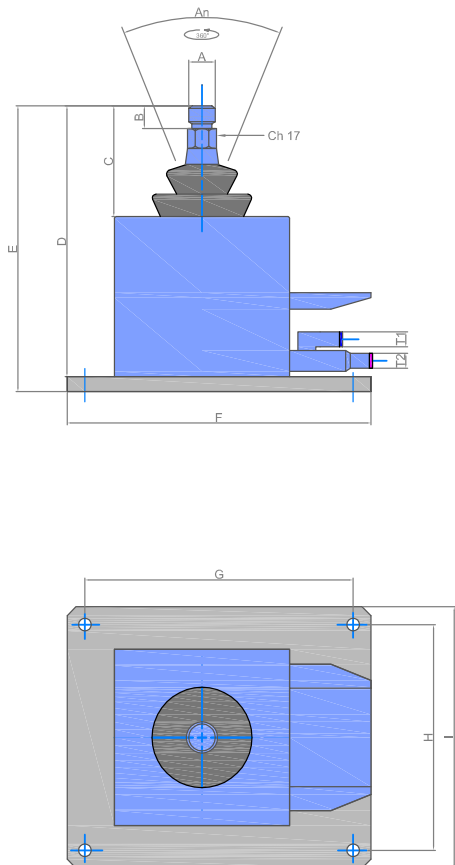

General Dimensions (mm)

A	B	C	D	E	F	G	H	I	T1	T2	An
M18	16	74	190	200	205	181	151	175	Tu 6	Tu 4	70°

Working Pressure : from 4 to 9 bar Max  
 Working Temperature: -10° +60°C

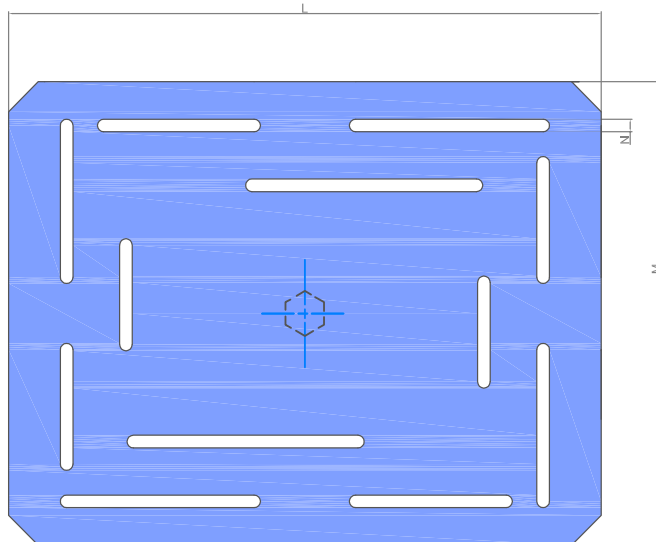
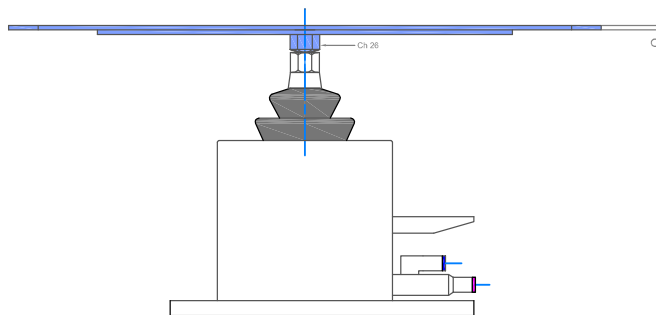

Standard equipment Platform (mm)

L	M	N	O
400	310	8,5	3

Material : AISI 304

Maximum force allowed (Fr) on the Platform when locked

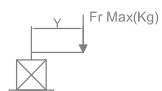

Y(mm)	150
bar	4 6 8
Fr (Kg)	30 42 55



**PSET di Lavelli Fabio**

Via Giovanni Alberti, n° 42/B - 27053 Lungavilla (PV) - ITALY

Ph.: +39 320 032 5818

Email: [p-set@outlook.com](mailto:p-set@outlook.com) | Web: [www.p-set.com](http://www.p-set.com)